

ENHANCING SPATIAL IMAGINATION OF YOUNG STUDENTS BY ACTIVITIES IN 3D ELICA APPLICATIONS

Pavel Hristov Boytchev¹, Toni Kondeva Chehlarova², Evgenia Yovkova Sendova³

Abstract: The paper presents research activities carried out within *DALEST* (Developing an Active Learning Environment for the Learning of Stereometry). Some of the computer 3D applications based on Elica are considered together with possible educational scenarios.

Key words: stereometry, spatial sense and reasoning, visualization, computer applications, Elica

1. THE IMPORTANCE OF ENHANCING THE *SPATIAL INTELLIGENCE*

Space is a fundamental category of thought, one that plays a deep role in many aspects of human cognition. *Because space is a fundamental feature of our environment, spatial knowledge and spatial perception play crucial roles in even the most ordinary human problem solving* [1]. Furthermore, the ability *to think in pictures, to perceive the visual world accurately, and recreate (or alter) it in the mind or on paper*, called in short *spatial intelligence*, is identified as one of the seven different kinds of intelligence [2].

As discussed in [3] the development of students' spatial imagination is still a problem which is not fully solved in Bulgarian Mathematics Education. According to the current syllabus some knowledge of prism, pyramid, cone, cylinder, ball and sphere should be formed during the compulsory education in 6th grade. Superficial knowledge of Solid Geometry is learned as a profiling subject in 11th and 12th grades. The new syllabus includes the topics of cube and rectangular parallelepiped in 5th grade. But in the textbooks for the rest of the grades one wouldn't find even sporadic problems targeted at developing the students' spatial sense.

A possible way to improve the situation is to provide students with possibilities to explore the properties of 3D objects in **appropriately developed computer applications**. Since children's initial representations of space are based on action an important feature of such applications is that they should be *action-based*, i.e. the students should be able to:

- *slide and rotate 3D objects creating dynamic images;*
- *combine 3D objects in more complex compositions;*
- *measure the basic 3D objects and study their properties and relationships;*
- *represent and solve problems using geometric models.*

When provided with **carefully designed sequences of educational activities** within such computer applications the students are expected to *develop an appreciation of geometry as a means of describing the physical world*.

All the above skills and competencies are identified by the math educators as crucial for the development of the spatial sense in 5-8 graders [4].

2. THE *DALEST* PROJECT

Such computer applications and educational activities are being developed under the *DALEST* project (**D**eveloping an **A**ctive **L**earning **E**nvironment for the Learning of **S**tereometry) whose goal is to enhance middle school students' 3D geometry understanding and spatial visualization skills by working with dynamic visualization images [5]. The theoretical background behind the design of the *DALEST* software has been considered in details in [6]. The applications we are considering in this paper (*Cubix Editor, Slider, Potter*

¹ University of Sofia, Bulgaria: elica@fmi.uni-sofia.bg

² Plovdiv University "P. Hilendarski", Bulgaria, tchehlarova@mail.bg

³ Bulgarian Academy of Science, Institute of Mathematics and Informatics: jsendova@mit.edu

Wheel, Math Wheel, Origami Nets and Scissors) are a subset of DALEST applications developed in *Elica* - a modern Logo implementation providing tools for real-time 3D animation of user-programmable objects [7]. In harmony with the constructionism [8], these applications support educational activities that encourage the students to create and design mathematical objects.

The current phase of DALEST embraces the development of sequences of pedagogical scenarios expected to be *rich in content, visual in nature, related to the world and consonant with the need of the students for self-expression*.

After over viewing the DALEST applications in a nutshell we give possible pedagogical scenarios in an attempt to illustrate their teaching/learning potential.

3. THE CUBIX EDITOR

3.1 Short Description

The *Cubix Editor* allows the construction of 3D structures of unit-sized cubes only by clicking. The students can also re-color the cubes and get measures for the volume and surface area of the constructions. They can load such structures from a library and enrich it by saving their own compositions. A very useful characteristic of the application is the rotation of the whole platform of the construction, a manipulation which allows the user to visualize dynamically the front, side and top view of the composition. Below a possible scenario for working with the *Cubix Editor* is given (as suggested in *I Work and Create with a Computer* – a project for an IT textbook for 6th grade in the Bulgarian schools).

3.2 Pedagogical Scenario

Challenge: *Change the place of one of the unit cubes in Fig. 1 so that the new construction could take the position of Fig. 2 in the space.*

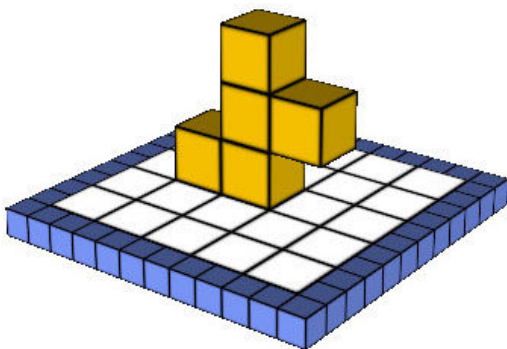

Fig. 1 Initial configuration

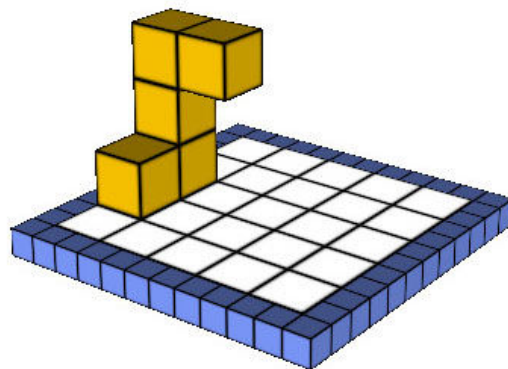

Fig. 2 Final configuration

Warm up

Build the compositions of unit-sized cubes following the sequences shown in Fig 3:

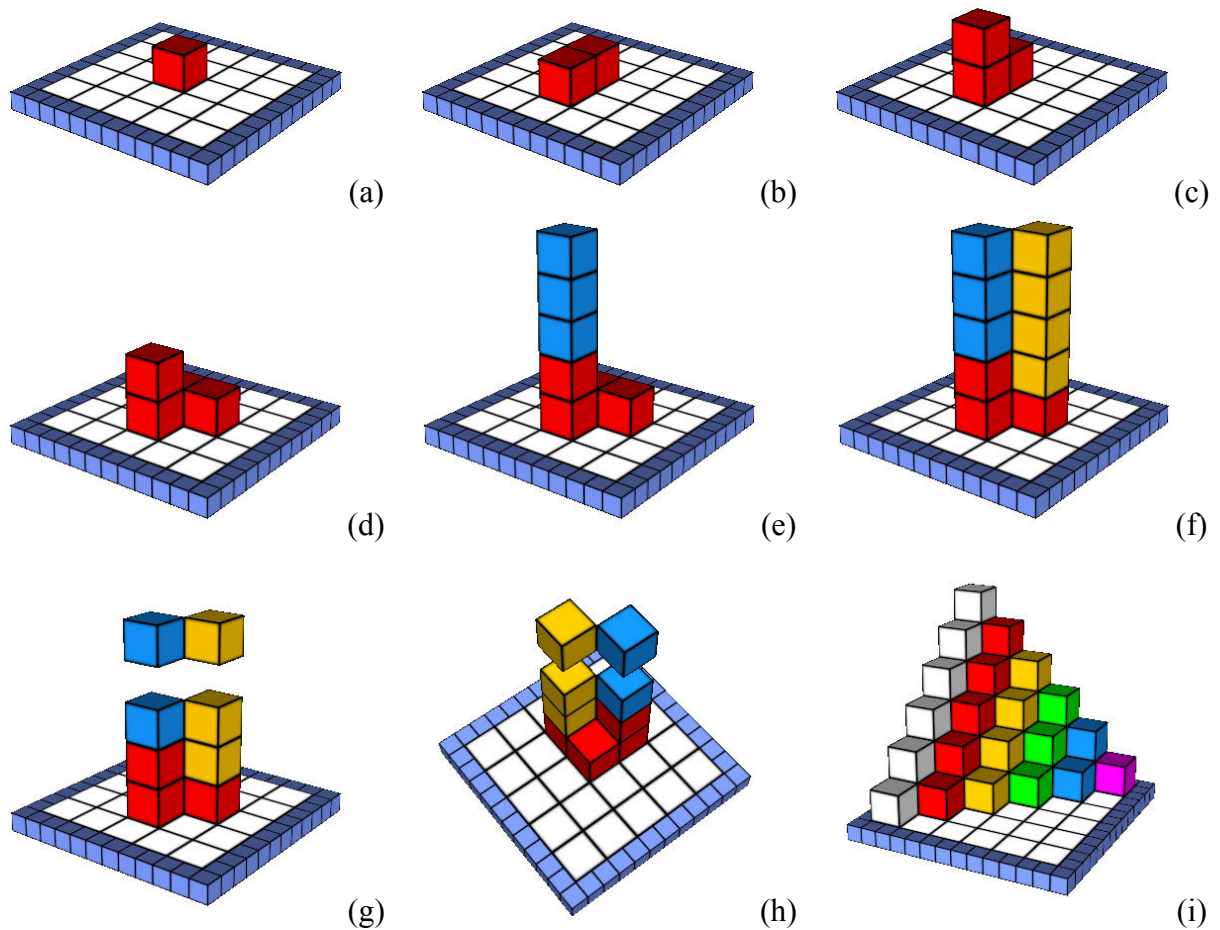

Fig. 3 A sequence of structures to be built using the Cubix Editor

And now create

- Solve the challenge by means of the Cubix Editor. Load the construction Fig.1 from the library of constructions and figure out which unit cube you should move to a new place.
- Think of a new logical problem similar to the challenge and create a document with the text of the problem and appropriate illustrations.
- Build a composition in the style of a famous building (Fig. 4)
- Build a composition in the style of Vasarely (Fig. 5)

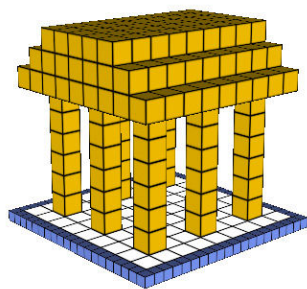

Fig. 4 The Parthenon

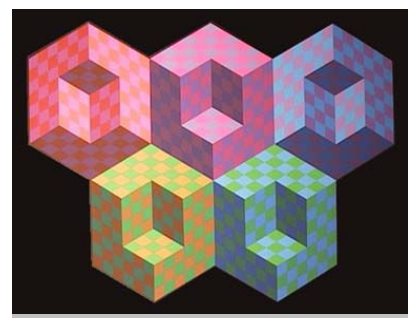
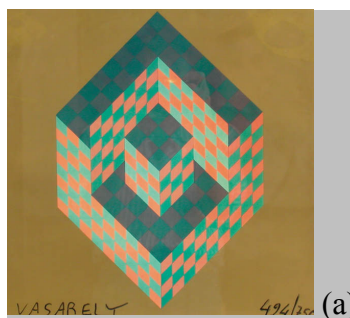

Fig. 5 Compositions by Vasarely

Investing architecture through geometric language and blending geometry and art is also very important issue promoted by many math educators [9].

4. THE SLIDER

4.1 Short Description

The students have a *magic* cube with an invisible 3D object in it (Fig. 6). They can control a laser plane by moving it along any of the axes. The places where the plane cuts the invisible object become visible, i.e. the students can view the intersection between the plane and the object. They can also rotate the whole *magic* cube together with the invisible object in it and examine it from various point of views. The goal is to guess the type of the invisible object by inspecting its intersection with the laser plane. The students can make the hidden object visible by a help button. In this mode they can study why the intersection has one or another shape (Fig. 7-8). The system has 16 different objects (cubes, spheres, cones, cylinders, pyramids, to name just few of them) shown at various orientations. After guessing which the invisible object is in a number of situations the students can be involved in a reverse activity – to guess the intersection of an object with a plane. Such an activity can be formulated in a more attractive scenario, inspired by [10].

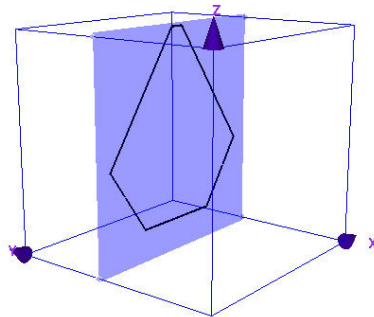

Fig. 6 The *magic* cube and the *laser* plane

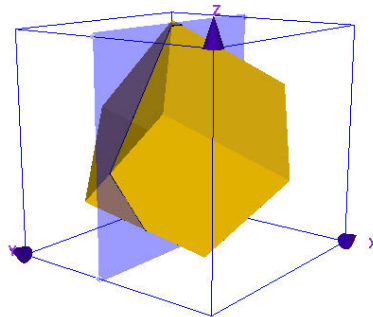

Fig. 7 An intersection of a cube and a plane

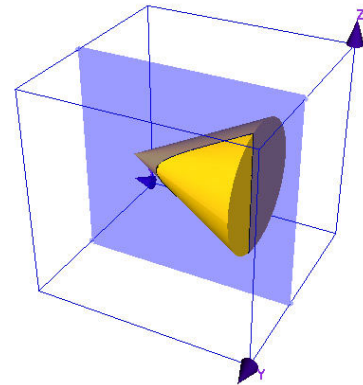

Fig. 8 An intersection of a cone and a plane

4.2. -Educational Scenario - *Meteorites in Flatland*

Challenge: *Imagine intelligent 2D aliens who live in Flatland – they have no facilities to sense anything out of their world. If a meteorite of a cubic shape collides with and passes through Flatland how the Flatlanders might observe this astronomical catastrophe?*

Using the Slider explore situations depending on how the cube approaches Flatland:

- *the cube leads with its sharp point the Flatlanders*
- *the cube makes first contact along one edge*
- *the cube falls at angle (not perpendicularly to Flatland surface)*

Imagine that the meteorite has another shape and predict what the Flatlanders would see.

5. POTTER'S WHEEL

5.1 Short description

The main idea in the *Potter's Wheel* application is that the students have a simple object which can be moved and rotated. The object under rotation could be a segment, a circle, a square, a triangle, a sinuoidal curve or a freely transformable curve passing through 5 given points - a chain of Bezier curves (Fig. 9). The user sees an axis on the screen and the object positioned on the left, on the right or across that axis. When the user has fixed the position of the object, the application rotates it around the axis and produces a 3D rotational image (Fig. 10). This process is similar to the way potters use clay and a wheel to make pottery.

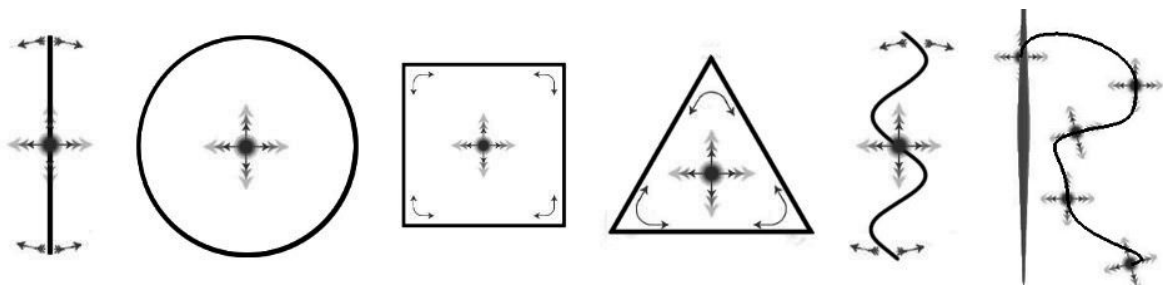

Fig. 9 Objects under rotation in *the Potter's Wheel*

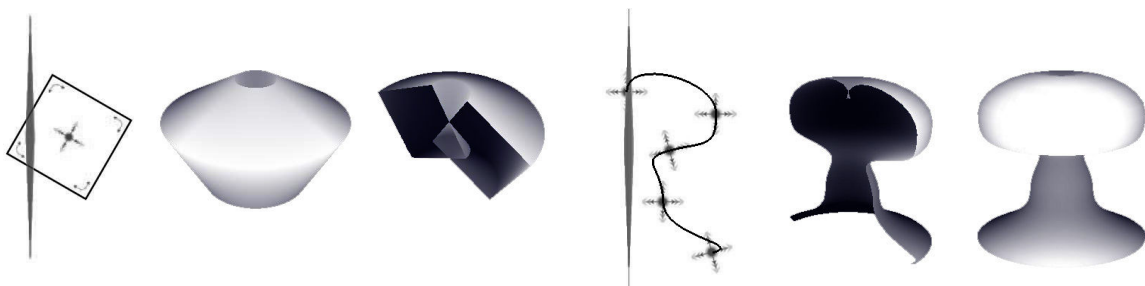

Fig. 10 Rotational images of a square and a free curve in the *Potter's Wheel*

5.2 Educational Scenario

Challenge: *A potter's hands press the clay toward the center of the wheel upon which the clay is placed while the wheel is turning around. Before starting to work with the clay the potter draws a profile of the vessel. Help the potter with making a profile for the objects in Fig. 11.*

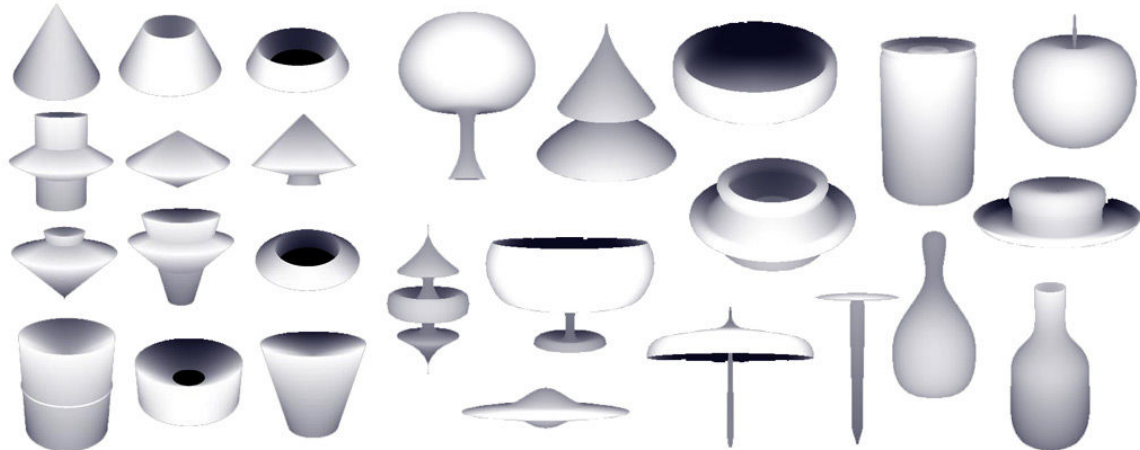

Fig. 11 Models of rotational objects

Hint. Check your answer with the Potter's Wheel

6. THE MATH WHEEL

6.1 Short description

The *Math Wheel* is similar to the *Potter's Wheel*. The user has three main objects to rotate - a triangle, a quadrangle and a circle. Their vertices can be dragged and the volume and surface of the rotational solids can be calculated along with the display of the 'algorithm' (Fig. 12)

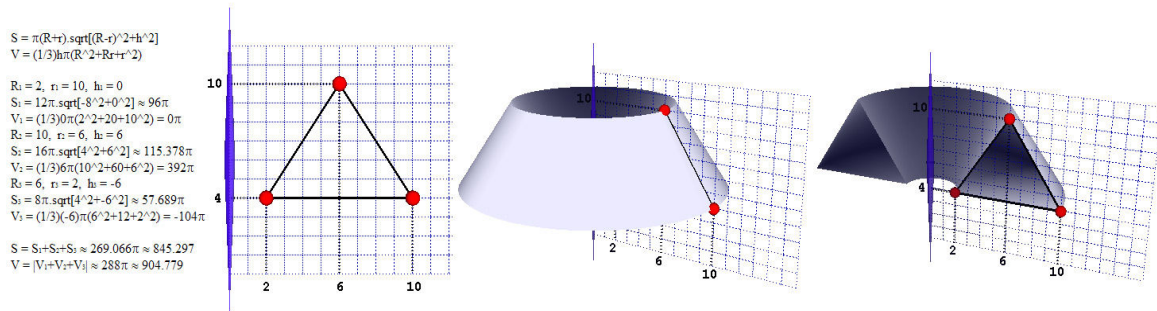

Fig. 12 A triangle under rotation and the calculations of solid's surface and volume

6.2 Educational Scenario

Challenge: A firm wants an advertisement in the shape of a 10x2 rectangle turning around one of its sides. The tax depends on the space taken by the ad while it turns. Figure out which of the two adjacent sides should be the axis of rotation so that the tax is smaller.

Hint: Construct a model to help you explain, using the Math Wheel (Fig.13). Use the Math button to check your calculations.

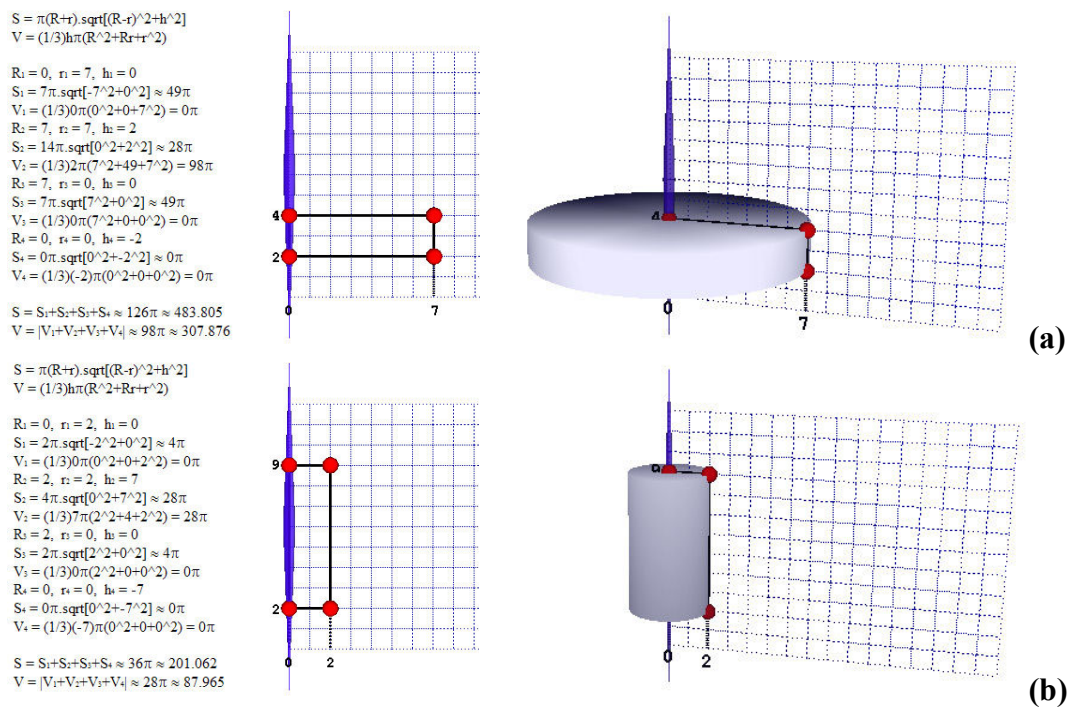

Fig.13 Comparing the volume of the cylinders formed by a rectangle

7. ORIGAMI NETS

7.1 Short description

Origami Nets is the most complex application in the project. It allows the students to build freely foldable nets using a set of 2D shapes. The shapes can be attached (or glued). Then each joint between two shapes can be folded to any degree. In this way students create various solids – cubes, cuboids, prisms, truncated prisms, cones, and compositions of solids (Fig. 14). An interesting challenge in the application is to construct more complex objects, e.g. a ball made of octagons, hexagons, squares and triangles (Fig. 15):

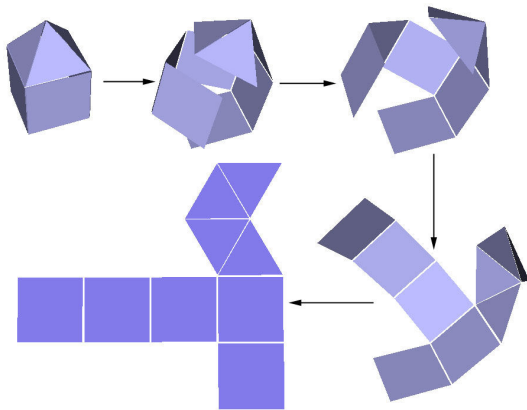

Fig. 14 Constructing a house and its net

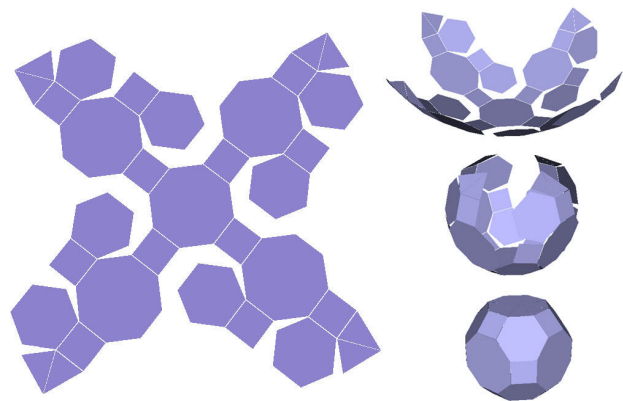

Fig. 15 Creating a ball from 33 polygons

7.2 Educational Scenario

Challenge: Which compositions of squares in Fig. 16 are not nets of a cube?

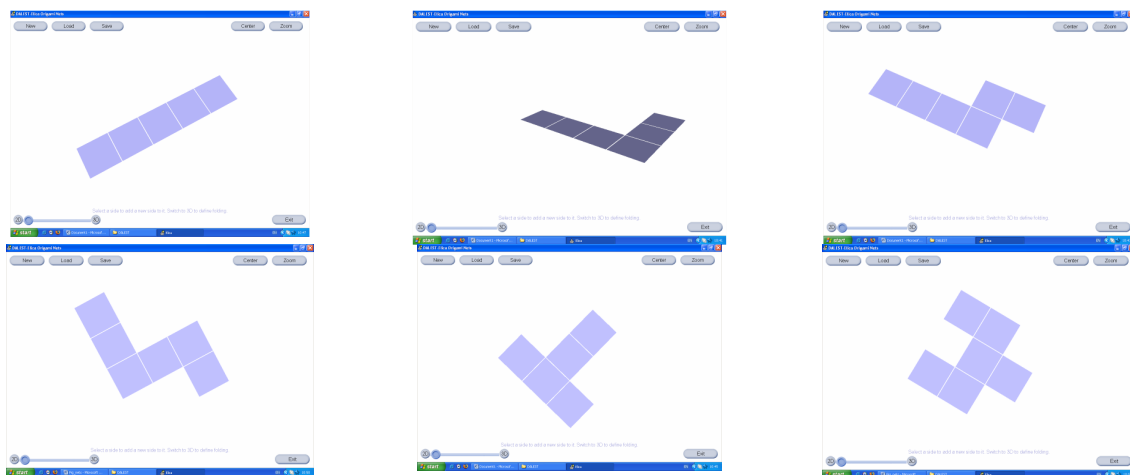

Fig. 16 Identifying compositions of squares which are not nets of a cube

Hint: Check your answer by means of *Origami Nets*

8. SCISSORS

8.1 Short description

In the *Scissors* application a cube (or other 6-faced objects) and small scissors could be manipulated with. When clicking on scissors the edge they are pointing at is ripped off. This allows for solving the reversed problem of net folding.

8.2 Educational Scenario

Challenge: Draw a cube. Point at the edges of the cube you would like to rip off so that the remaining figure could be unfolded in the net shown in the rightmost of Fig. 17.

- Check your solution by means of the Scissors program.
- Select another 6-faced toy (Fig. 18). and formulate a similar problem of your own

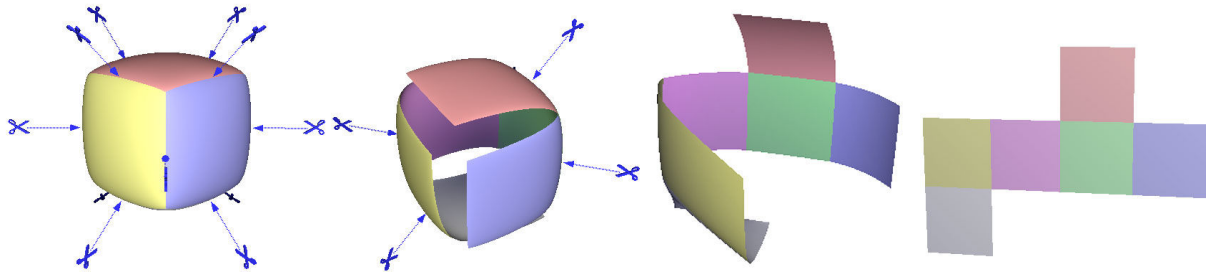

Fig 17: Ripping and unfolding a cube to a net

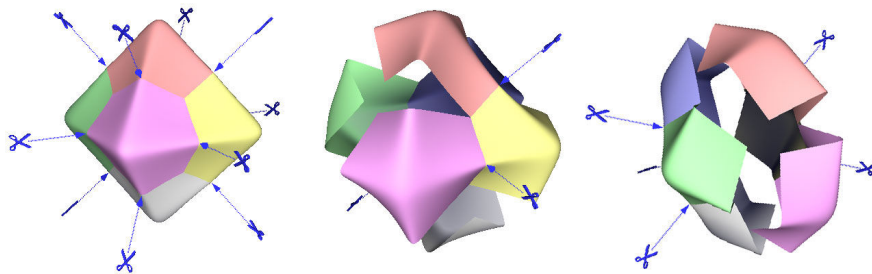

Fig 18: An overripped octahedron cannot be unfolded into a single net

9. IDEAS FOR FURTHER APPLICATIONS

9.1 Playing Archimedes

This application will allow the students to put 3D objects of various shapes (cubes, spheres, cylinders, cones) in a bath-tubs and measure their volume by measuring the changes in the water level (Fig. 18.). A virtual ruler will be used to measure distances and sizes. The same ruler is used to measure the level of the water.

A possible extension of this problem is to allow partial submerge objects.

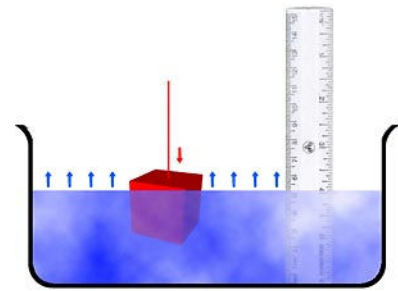

Fig 19: Playing Archimedes

9.2. Bottle Factory

Organized as a game, this application will allow students to design perfume bottles so that they could contain a predetermined amount of perfume (Fig. 19). The shape of the bottles could vary (cube, parallelograms, spheres, hemispheres, etc...) and the size could be controlled by the student. A specific task would be to design a bottle of a given shape and a given volume.



Fig 20: Bottle Factory

10. FIRST IMPRESSIONS

The educational activities within DALEST are still under development but some scenarios and possible projects have been discussed at the course for IT teachers for 5th and 6th grade delivered in Sofia and Blagoevgrad. Also, a workshop on Elica-based DALEST applications has been offered to the participants in the International Conference in Informatics in Secondary Schools, ISSEP 2006, Vilnius, November, 2006 [11]. The first reactions of the teachers were very positive and many of them expressed their own ideas of implementing the applications in their IT and math classes.

Here are some thoughts of 6 graders of a Plovdiv school after their first experience with *Origami Nets* and *Scissors*:

- *I like the problem with unfolding a cube into a given net the most. This activity was very amusing.*
- *I like it a lot when passing from 3D to 2D mode –trying to predict what the net would be was very interesting for me.*
- *For me the best part was to make a net first and then fold it into a solid.*
- *I liked the programs because you can understand what the nets are and you have to think when making a net yourself.*



Fig. 21. *Students working with Origami Nets*

The third year of the project (2007) is dedicated on the dissemination of the materials and trying them out in various class settings.

Acknowledgements

This project was part-funded by the European Union (grant 224269-CP-1-2005-1-CY-MINERVA-M). The views expressed are those of the authors and do not necessarily reflect the views of the EU or any of its sub-agencies. The authors acknowledge the contribution to the project of all members of the project consortium.

REFERENCES

1. Report on The National Science Foundation Research Planning Workshop (1997), http://www.princeton.edu/~jjg/nsf_report.html
2. Gardner, H. (1993) *Frames of Mind*, New York: Basic Books.
3. Grozdev, S., T. Chehlarova (2005). *Cube constructions*. Proc. 3rd Congress of Mathematicians of Macedonia, Struga, 29.09. – 02.10.
4. National Council of Teachers of Mathematics (2000), '*Principles and standards for school mathematics*', Reston: Va, NCTM
5. DALEST project: <http://www.ucy.ac.cy/dalest/>
6. Christou, C. et al (2006), *Developing Student Spatial Ability with 3D applications* (submitted to CERME)
7. Boytchev, P., *Elica*, <http://www.elica.net>
8. Papert, S. (1991). Situating Constructionism. In I. Harel and S. Papert (eds.), *Constructionism*. (1-11). Norwood, NJ Ablex,
9. Lowrie, T. (2002), The influence of visual and spatial reasoning in interpreting simulated 3D worlds, *International Journal of Computers in Mathematical Learning*, 7(3), 301-318.
10. Moscovich, I. (2004) *Leonardo's Mirror & Other Puzzles*, Sterling Publishing Co., Inc. NY, p.89
11. Boytchev, P. Demonstration of DALEST-Elica educational software, Proceedings of 2nd International Conference ISSEP 2006, Vilnius, November 2006, <http://ims.mii.lt/issep/prog.html>

Стимулиране на пространственото въображение на учениците чрез дейности в тримерни приложения на образователния софтуер ELICA

Павел Х. Бойчев, Тони К, Чехларова, Евгения Й. Сендова,

Абстракт: Представена е работата на авторите в рамките на проекта DALEST (Developing an Active Learning Environment for the Learning of Stereometry). Целта на проекта е да се стимулира пространственото въображение на учениците от 5. и 6. клас с подходящи дейности в специално създаден за целта образователен софтуер. В доклада са представени някои от приложенията, разработени в компютърната среда *Elica*, заедно с идеи за дидактически сценарии.